

Why you should consider the Series 80-DI Knife Gate Valves!

- Heavy duty cast ductile iron body, packing gland, and yoke for the most rugged service.
- Through bolting on side flange bolts allows easy installation.
- Easily replaceable natural rubber seat provides bi-directional drip tight seal across the blade from 0 to 150 PSI. Also available in EPDM and Buna-N.
- Seat is flush with the bottom of the port eliminating pockets in the bottom of the valve that may collect material in media such as slurries, pellets or powders.
- Rubber seat has a molded-in steel reinforcement and is bolted in place to prevent shifting out of position by blade movement.
- Machined stainless steel blade provides corrosion resistance and durability.
- Easy conversion from handwheel operator to hydraulic or pneumatic cylinder, bevel gear, chain wheel, electric motor, or fail safe spring cylinder operator using existing cast yoke.
- Enclosed bronze stem nut provides reduced operating torque and is protected from harsh environments.
- Stainless steel stem resists corrosion.
- Full packing seal around blade minimizes the potential for packing leakage.
- MSS SP-81 and AWWA C520 face-to-face and flange dimensions.
- Minimum 4 bolt packing gland to ensure proper gland alignment in all valve sizes.
- Entire valve (inside and outside) is epoxy powder coated to provide corrosion resistance.

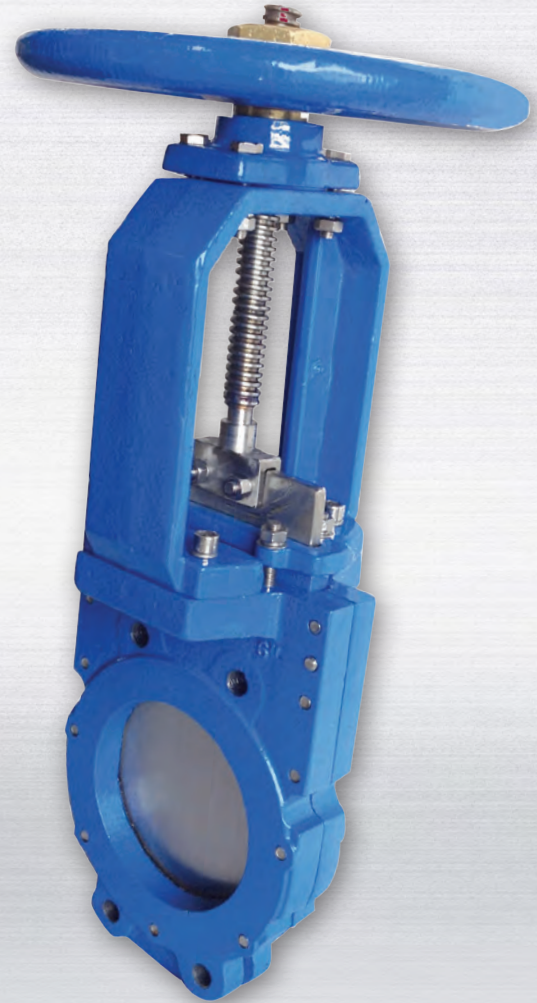

Where can you use the 80-DI Knife Gate Valve?

In thick media such as pulp stock or slurries

Dirty or muddy water

In Power plant fly-ash service

Wherever a cost effective utility valve is needed



Materials of Construction

Model	80-DI
1 Gate	SS
2 Body	DI
3 Seat	Natural Rubber*
4 Bolts	Stainless
5 Packing	TLSP**
6 Gland	DI
7 Stem	SS
8 Yoke	DI
9 Stem Nut	Bronze
10 Handwheel	DI

* Buna-N and EPDM seats also available.

**TLSP = TFE Lubricated Synthetic Packing.

Normally supplied with handwheel for manual operation, but can be modified for chain wheel, bevel gear, fail safe spring cylinder, electric motor, hydraulic or pneumatic cylinder operator.

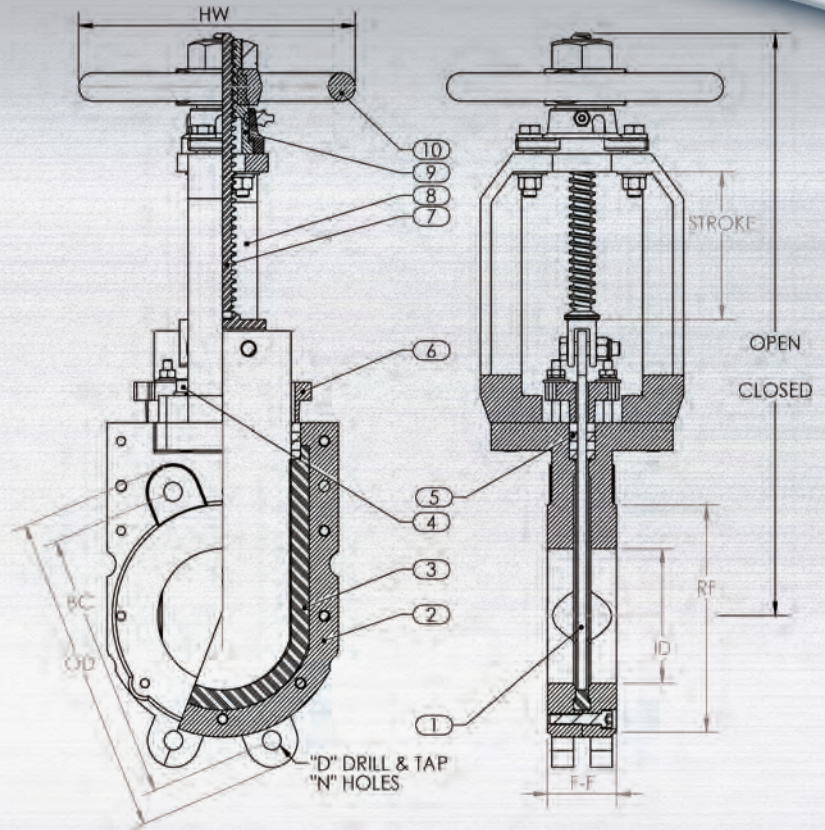

Dimensions (Inches) and Weights

	Size	2	3	4	6	8	10	12	14	16	18	20	24
Face-to-Face	F-F	1-7/8	2	2	2-1/4	2-3/4	2-3/4	3	3	3-1/2	3-1/2	4-1/2	4-1/2
Flange OD	OD	6	7-1/2	9	11	13-1/2	16	19	21	23-1/2	25	27-1/2	32
Bolt Circle	BC	4-3/4	6	7-1/2	9-1/2	11-3/4	14-1/4	17	18-3/4	21-1/4	22-3/4	25	29-1/2
Flanged Raised Face	RF	4-1/8	5	6-3/16	8-1/2	10-5/8	12-3/4	15	17	18-1/2	21	23	27-1/4
Inside Diameter	ID	2	3-1/8	4	6	8	10	12	13-3/4	15-3/4	17-3/4	19-11/16	23-5/8
No. of Bolt Holes	N	4	4	8	8	8	12	12	12	16	16	20	20
Hole D&T Size	D	5/8-11	5/8-11	5/8-11	3/4-10	3/4-10	7/8-9	7/8-9	1-8	1-8	1-1/8-7	1-1/8-7	1-1/4-7
C/L to Top-Closed	H-CLS	13	14-3/4	16-9/16	20-1/2	24-1/4	29	34-5/8	39	43	47-1/2	51-7/8	60
C/L to Top-Open	H-OPN	15	17-3/4	20-9/16	26-1/2	32-1/2	39-1/4	47	54-1/4	59	65-1/2	71-13/16	83-7/8
Handwheel Dia.	H/W	8	8	8	12	12	16	20	24	24	24	24	24
Weight - lbs	WT	24	34	40	84	116	170	258	308	418	516	702	932
Stroke	S	2	3	4	6	8-1/4	10-1/4	12-3/8	14-1/4	16	18	19-15/16	23-7/8

Mail: P.O. Box 221 • Candler, FL 32111 • 10551 SE 110th St. Rd.

Phone: (800) 342-9920 • Fax: (352) 687-1862

www.townley.net

Disclaimer: The information presented herein is a general guide to our products. We make no warranties, expressed or implied, with respect to the accuracy or usefulness of the information contained. Townley reserves the right to change the technical specifications from time to time without notice. Use of any and all information in this document is done so at the discretion of the user. - 150826